

# Deep Borehole Disposal as a Potential Solution for HLW/SNF in Norway – Current Status and a First Generic Safety Assessment

SafeND 2023 – SESSION 04: Activities in international research programs and collaborations

Tilman Fischer, Hans-Joachim Engelhardt, Bernt Haverkamp, Toivo Wanne, Ansgar Wunderlich

# Outline

1. General information about the Norwegian Program
2. Central aspects of the DBD development
  - General concept development
  - Disposal canister design
  - Sealing of disposal borehole
  - TRL assessment
3. Safety assessment

# Radioactive Waste in Norway

- Responsible organization → 
- No commercial reactors, limited waste volume
- Radioactive waste from various industries and research reactors
- Disposal plan is to locate all necessary repository types at a single site:
  - Landfill-type repository for VLLW
  - Intermediate-depth repository for LILW
  - HLW either in DGR-type (similar to Finland and Sweden) or Deep Borehole Disposal



# General Concept Development

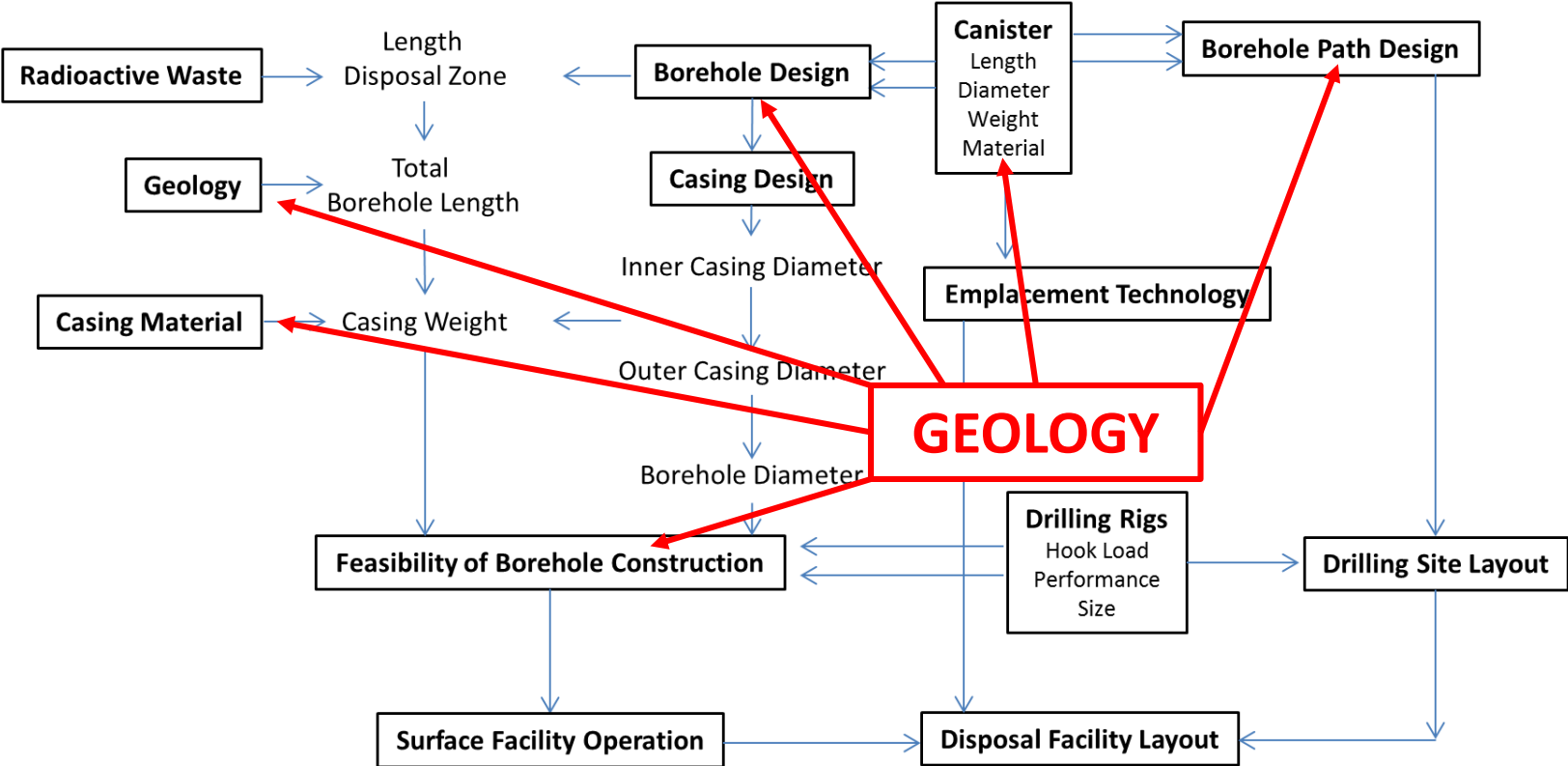

# General Concept Development

- Roughly 70 canisters (DBC-R) for the disposal of all Norwegian HLW/SNF in deep boreholes

- Considered canister dimensions:
  - Outer length: 5 000 mm
  - Inner length: 4 800 mm
  - Outer diameter: ~ 525 mm
  - Inner diameter: 435 mm

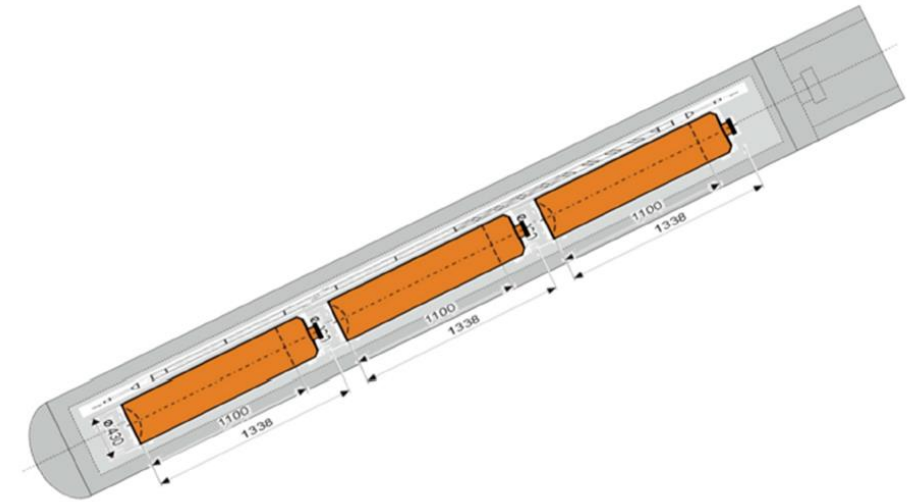

DBC-R container with three assemblies and one fuel rod

from: Bracke, G., Charlier, F., Liebscher, A., Schilling, F., Röckel, T. (2017): About the Possibility of Disposal of HLRW in Deep Boreholes in Germany. Geosciences, 7, 3.

- Resulting (preliminary) borehole dimensions:
  - Considered borehole depth: 3 500 m
  - Required disposal length: 500 m
  - Required inner casing diameter (at final depth): 600 mm

# General Concept Development

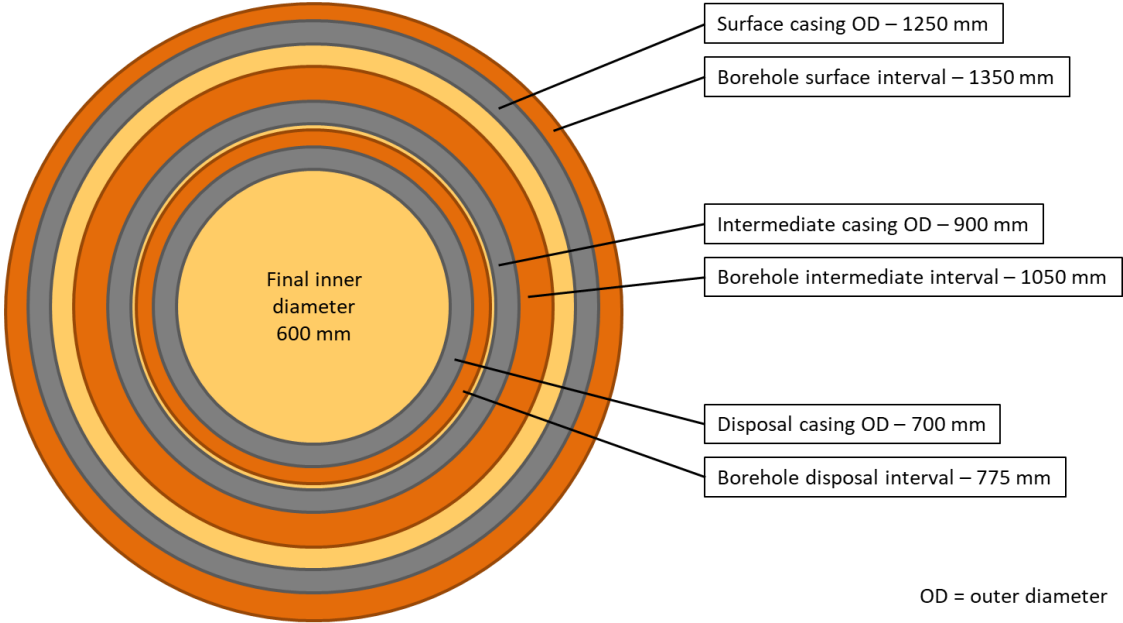

- Resulting borehole dimensions:
  - Considered borehole depth: 3 500 m
  - Required disposal length: 500 m
  - Required inner casing diameter (at final depth): 600 mm

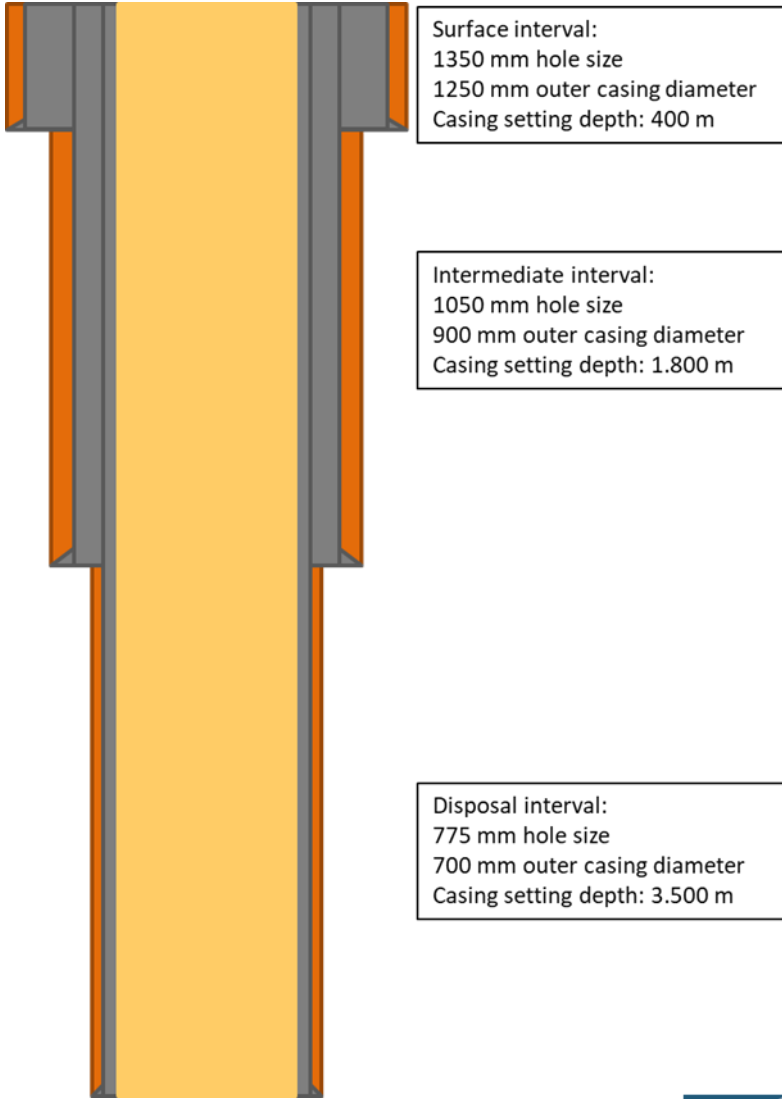

# Disposal Canister Design

## Safety functions:

For a radioactive waste canister, in general three major safety functions can be identified:

- **Containment** of the radioactive waste, e.g. as defined in IAEA SSR-5
- **Shielding** of the radiation, e.g. as defined in IAEA SSG-1
- **Absence of criticality**, e.g. as defined in IAEA SSG-15

Additional design- and concept-specific safety functions:

- **Limiting temperature** of the radioactive waste, e.g. as named in IAEA SSG-15
- **Limiting corrosion** and gas production, e.g. as named in IAEA SSR-5
- **Operability**, e.g. as named in IAEA SSG-1

## Quantified Safety Functions

## Physical design parameters:

- Canister is designed for all waste types
- Dimensions restricted by maximum lengths and diameters of fuel assemblies and waste packages from reprocessing

Analysis of potential materials and their benefits and limitations

Analysis of material availabilities

Analysis of potential manufacturing techniques

Physical dimension requirements of the canister

## Canister Design

## Manufacturing techniques:

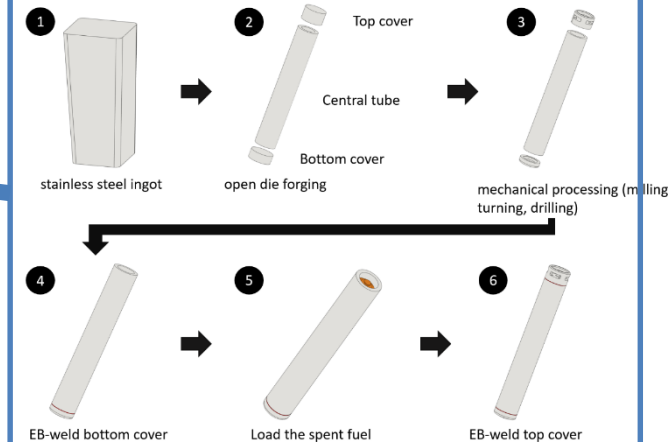

# Disposal Canister Design

Canister design for the HLW in Norway:

- Length about 4.4 meters
- Usable inner length ~3.7 meters
- Diameter 60 cm
- Material: Stainless steel
  
- Weight of empty canister ~4500 kg
- Weight with waste ~6000 kg
  
- For Norwegian HLW inventory, a total of 90 canisters are needed for a single disposal borehole

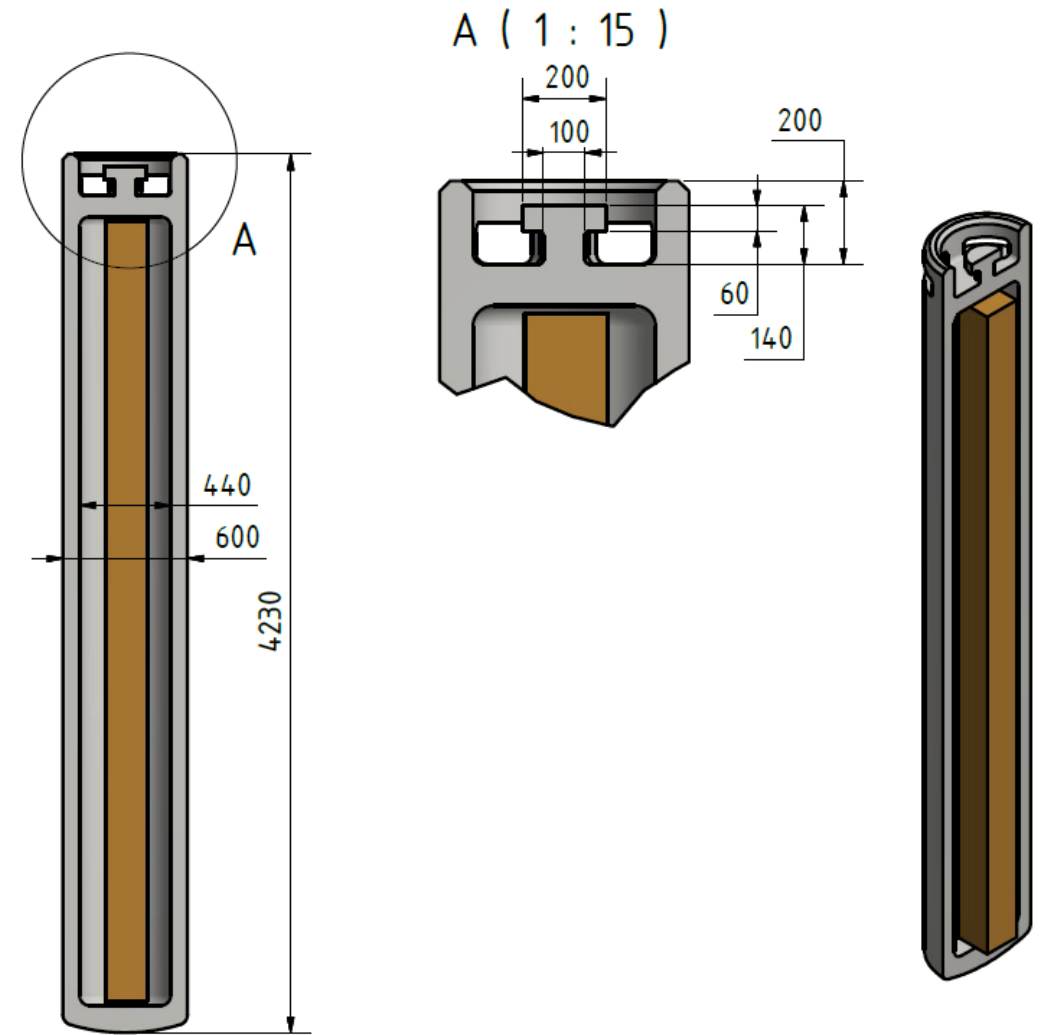



# Sealing of a Disposal Borehole

1. Gather information about the geology
    - Detailed information about formation sequences
    - Gamma ray-neutron logs
    - Investigation of cuttings and cores during drilling
    - Borehole pressure tests to identify potential fractures in the formation
    - Seismic surveys to detect faults
  2. Gather information about the borehole condition
    - Completion of the borehole
    - Condition of the borehole walls
    - Prepare the borehole for installation of the sealing elements
  3. Select material based on the geological/geochemical information
  4. Select emplacement method based on the material selection
  5. Determine the exact position of the sealing elements
- The main objective is to create a seal that mimics the formation!

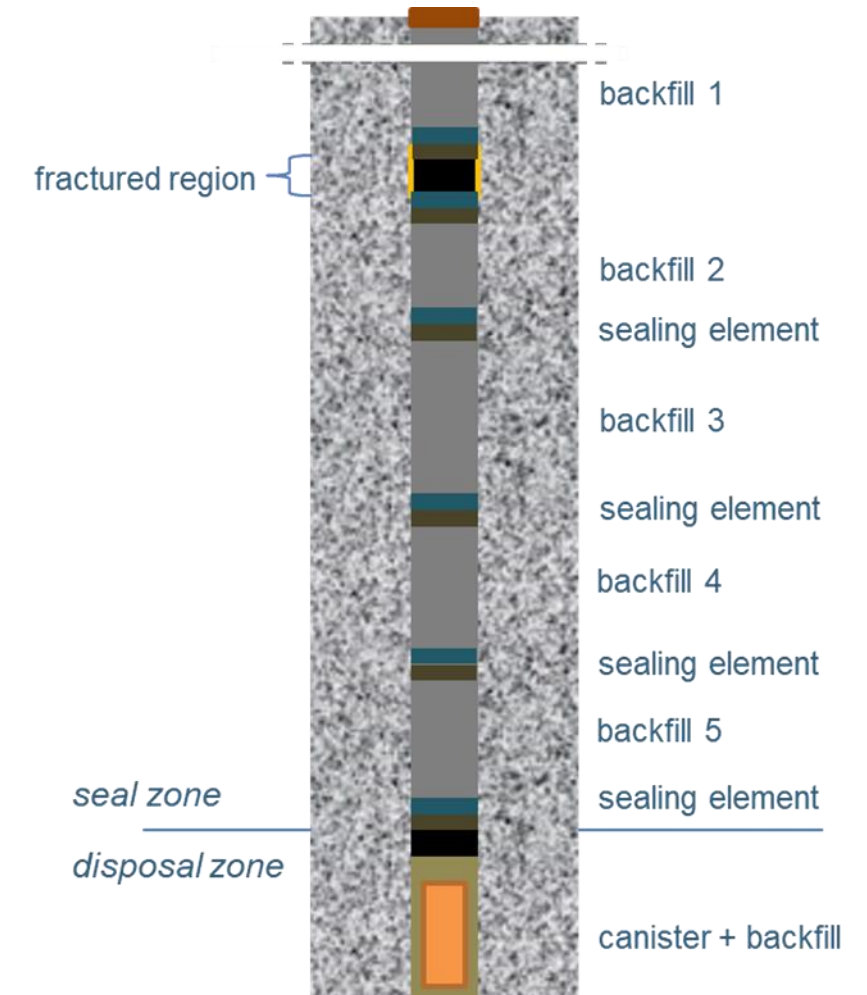

# TRL Assessment

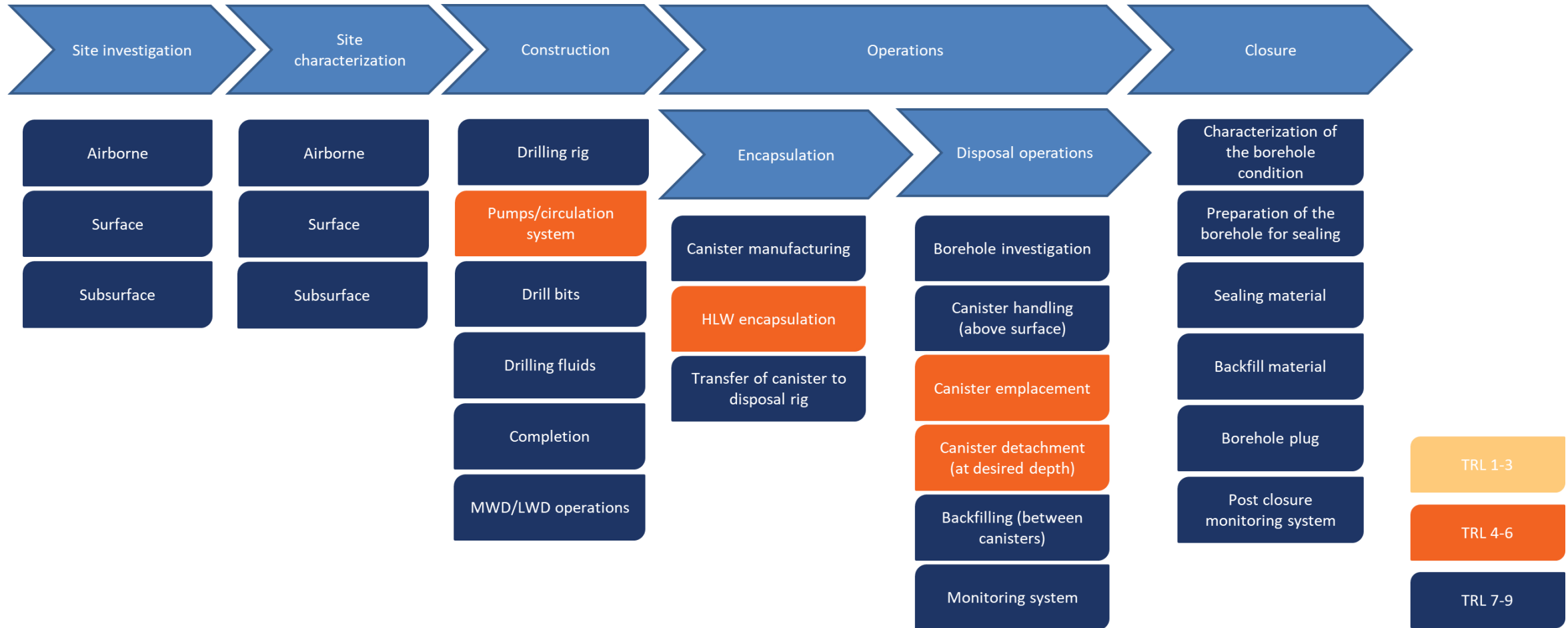

➤ Identification of aspects with the most R&D need

# TRL Assessment

- Findings of the first TRL assessment:
  1. Site investigation/identification capabilities are available and applied on a daily basis
  2. Drilling capabilities are in principle available and have proven their usability, however, the “required” dimensions have not/barely been drilled so far
    - When looking at the technical feasibility, availability of the technologies, and statements from drilling engineers, a borehole with the “required” dimensions can be drilled
    - The “right” components need to be put together
  3. Encapsulation plant, canisters, and emplacement device need to be developed
  
- In principle, all technologies are available and usable, but there is still a need for research to implement the DBD concept.

# Safety Assessment

## General information for the safety assessment

- Borehole assumptions:
  - Backfill zone length: 2,500 m (backfill material is a crushed rock mixture)
  - Sealing zone length: 500 m (seal consists of bentonite)
  - Disposal zone length: 460 m (88 canisters + 1 m bentonite buffer between the canisters)
- Canisters will fail, once thickness of canister walls has corroded from 80 mm initial thickness to 50 mm
- Calculations carried out with GoldSim

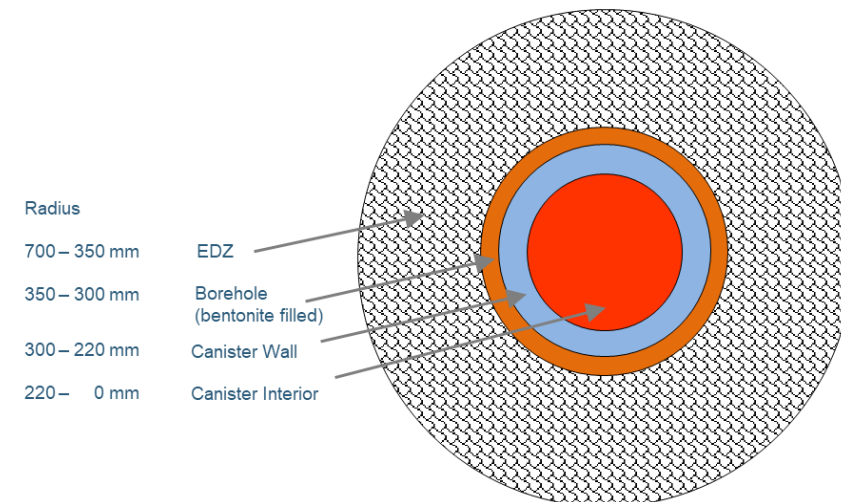

# Safety Assessment

- Sealing zone has been divided into 25 segments  
→ Each segment represents a 20-m-section
- Disposal zone has been divided into 22 segments  
→ Each segment represents 4 canisters (21 m)
- Backfilling zone has been divided into 25 segments  
→ Each segment represents a 100-m-section

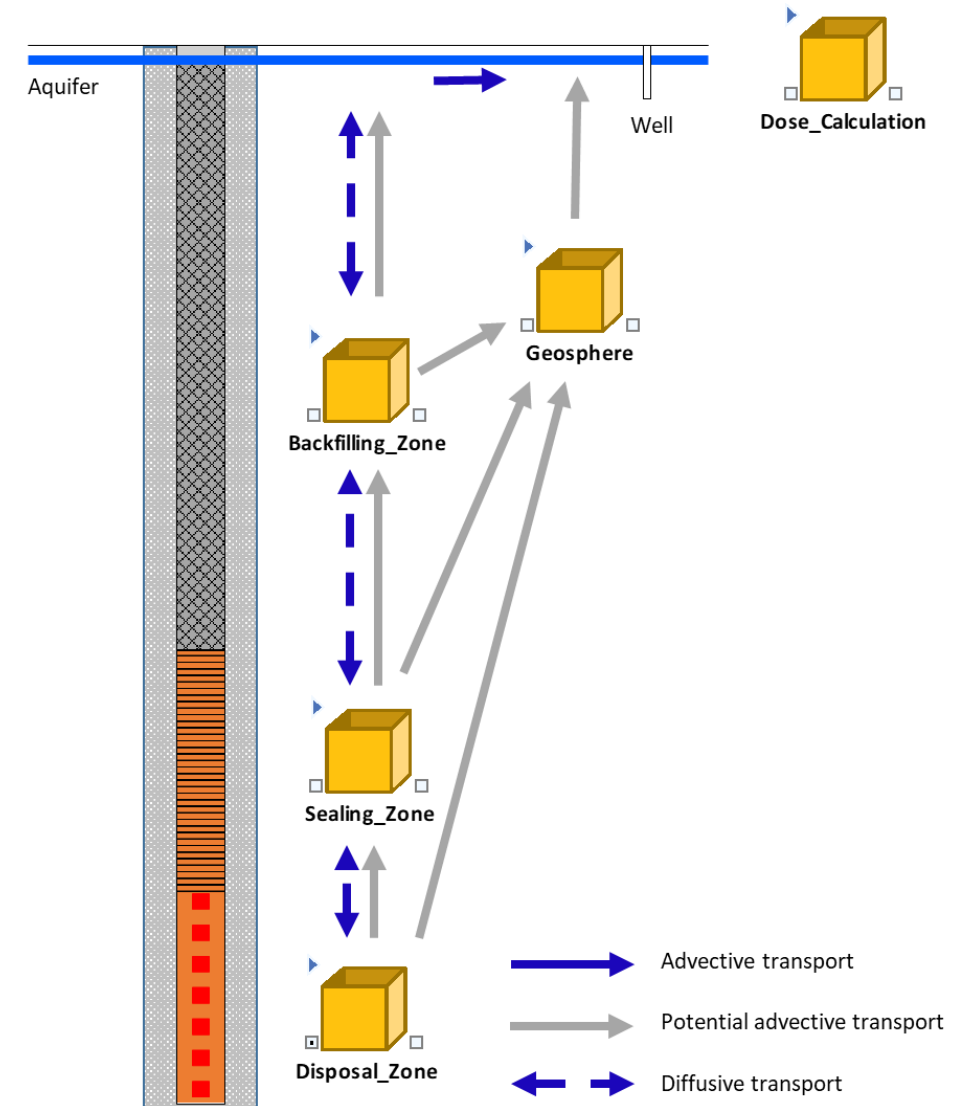

# Safety Assessment – SC-1

## Reference scenario - Normal Evolution Scenario – SC-1

- Only diffusive transport through the borehole and the damaged rock zone
- Advective transport through the groundwater aquifer to a water well

### Results:

- Sorbing radionuclides or those with relatively short half-lives do not reach the top of the seal
- Even non-sorbing radionuclides hardly reach the backfilling zone and the aquifer

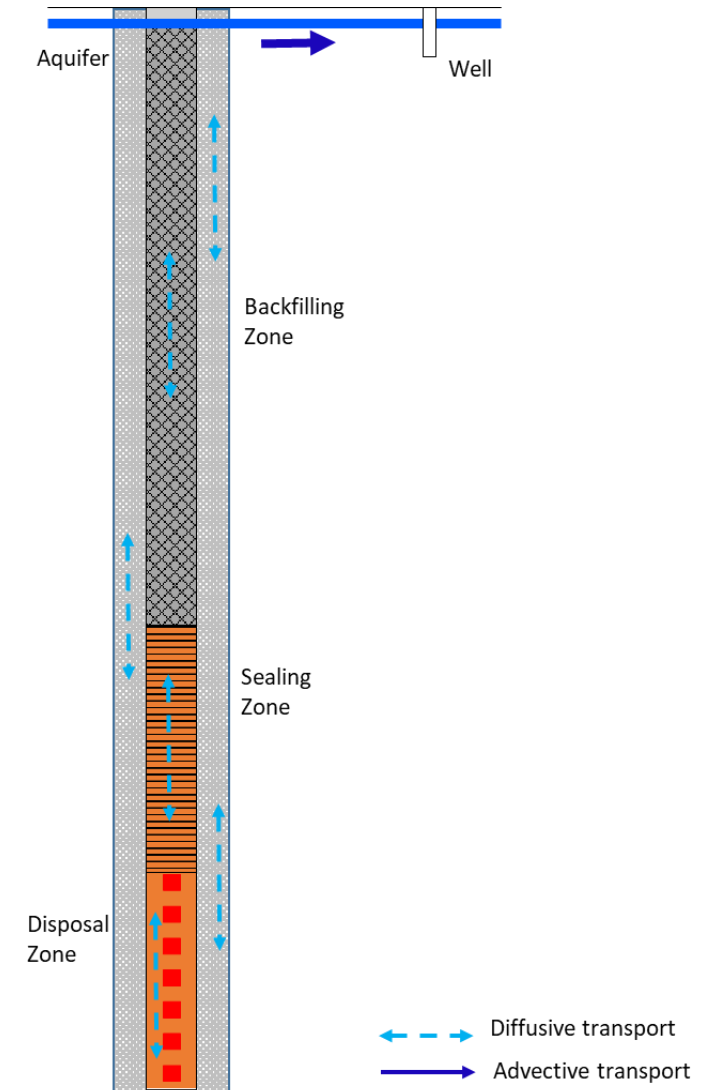
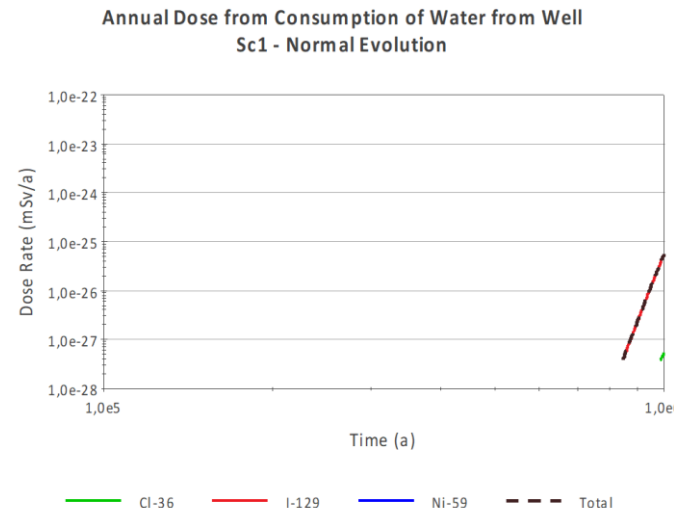

# Safety Assessment – SC-2

## Alternative scenario – Vertical Flow – SC-2

- Flow through the borehole and the damaged rock zone
- Different sub-scenarios considered
  - No solubility limits
  - No sorption
  - Direct failure of all canisters

### Results:

- Compared with SC-1, the total dose rate is larger → advective transport is much more efficient than diffusive transport
- Total dose rate is higher
- Dose rate is still well below the assumed regulatory limit (0.1 mSv/a) even for the pessimistic scenarios

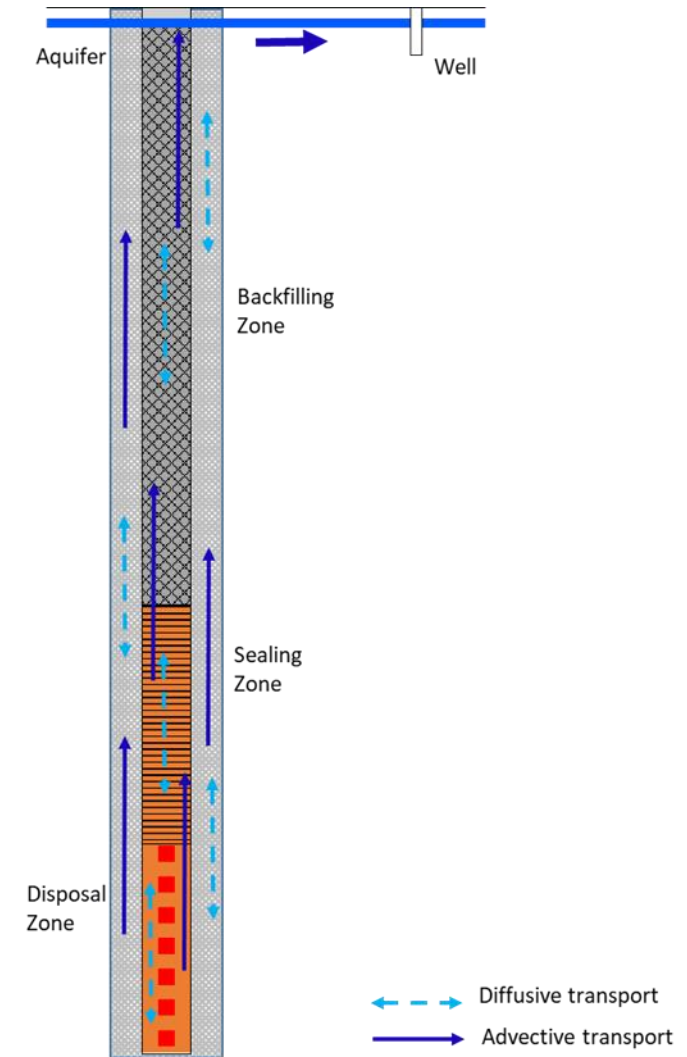

# Safety Assessment – SC-3

## Alternative scenario – Fracture – SC-3

- Flow through fractures
- Intersection of borehole by a highly transmissive fracture
- Fractures at different locations (depths) of the borehole considered:
  1. Bottom/middle/top of the disposal zone
  2. Middle of the sealing zone
  3. Bottom of the backfilling zone

## Results:

- Dose rate depends strongly on the location of the fracture
- Higher dose rate than before, especially for fractures through the disposal zone, but still below the regulatory limits

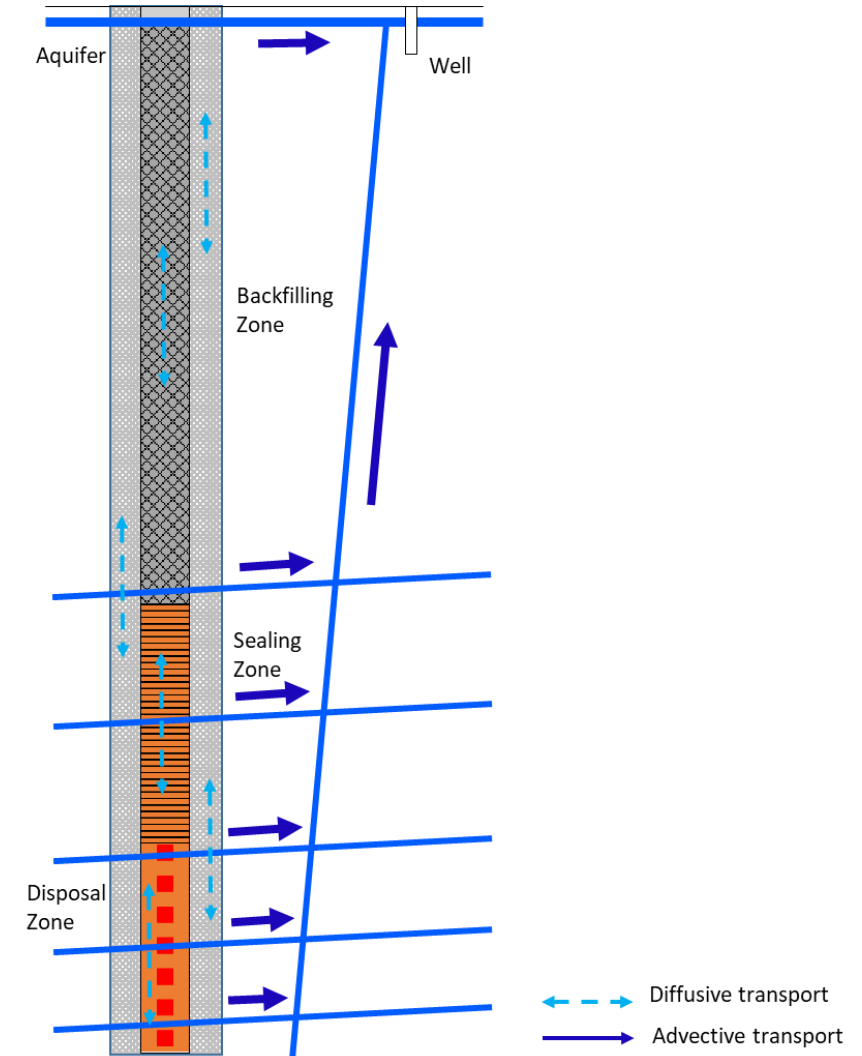
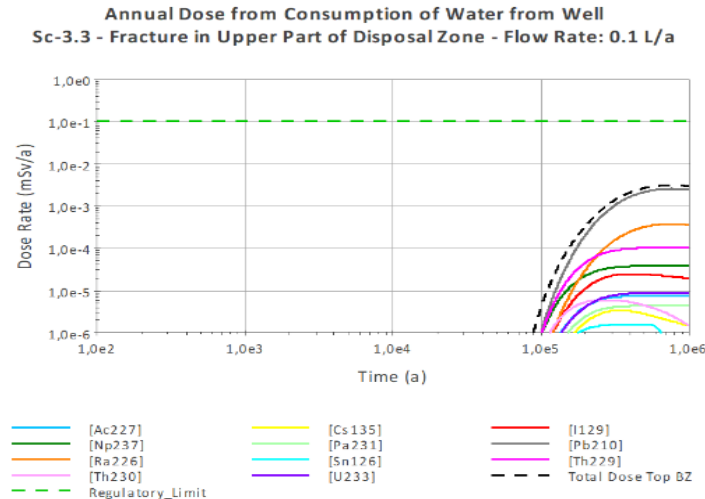





Thank you for your attention!